

Genetic analysis of glutamatergic signal transduction in alcohol dependence

Gunter Schumann, MD

Institute of Psychiatry

King's College, London

Neurobiological systems involved in alcohol addiction:

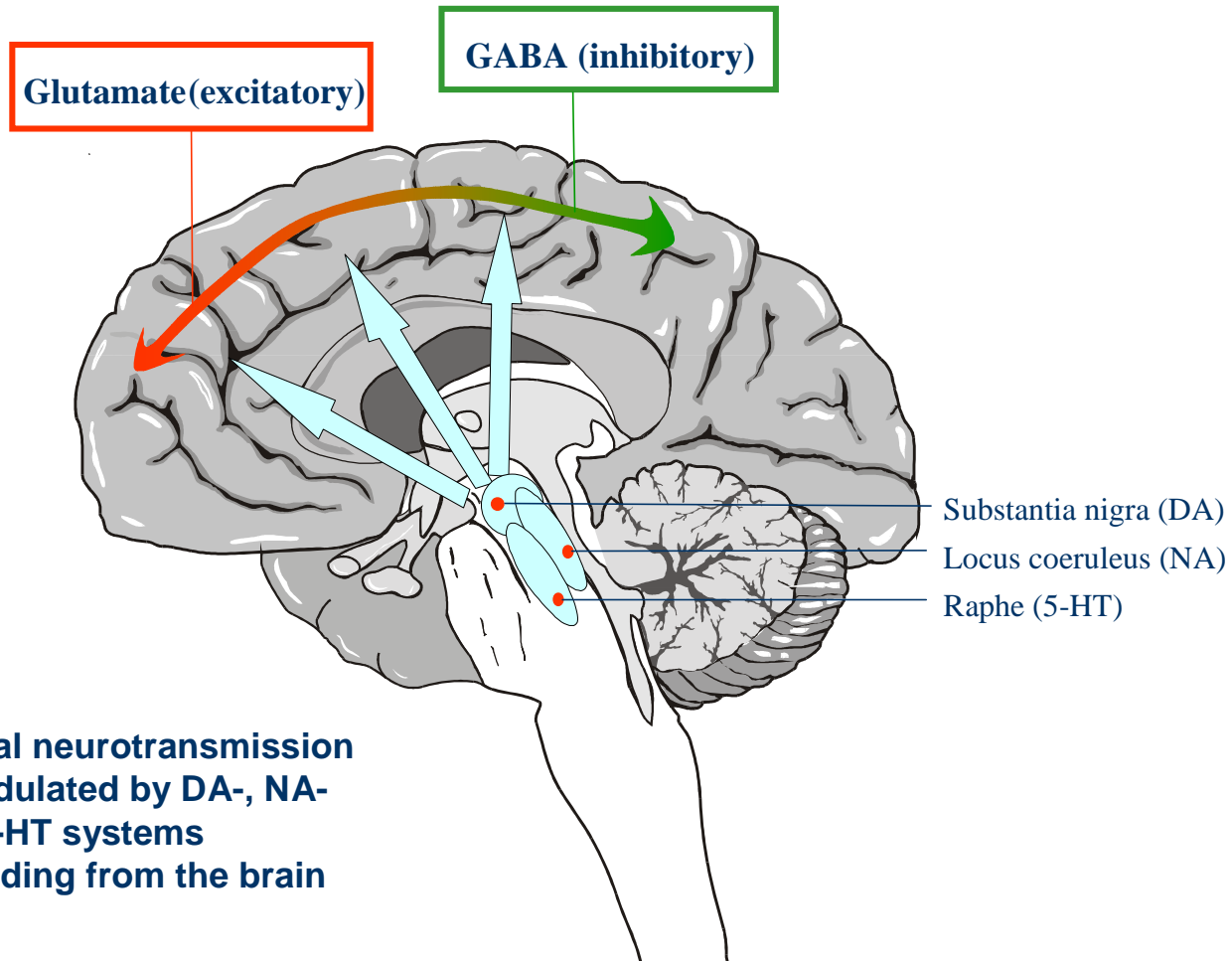

Effect of ethanol on glutamatergic neurotransmission:

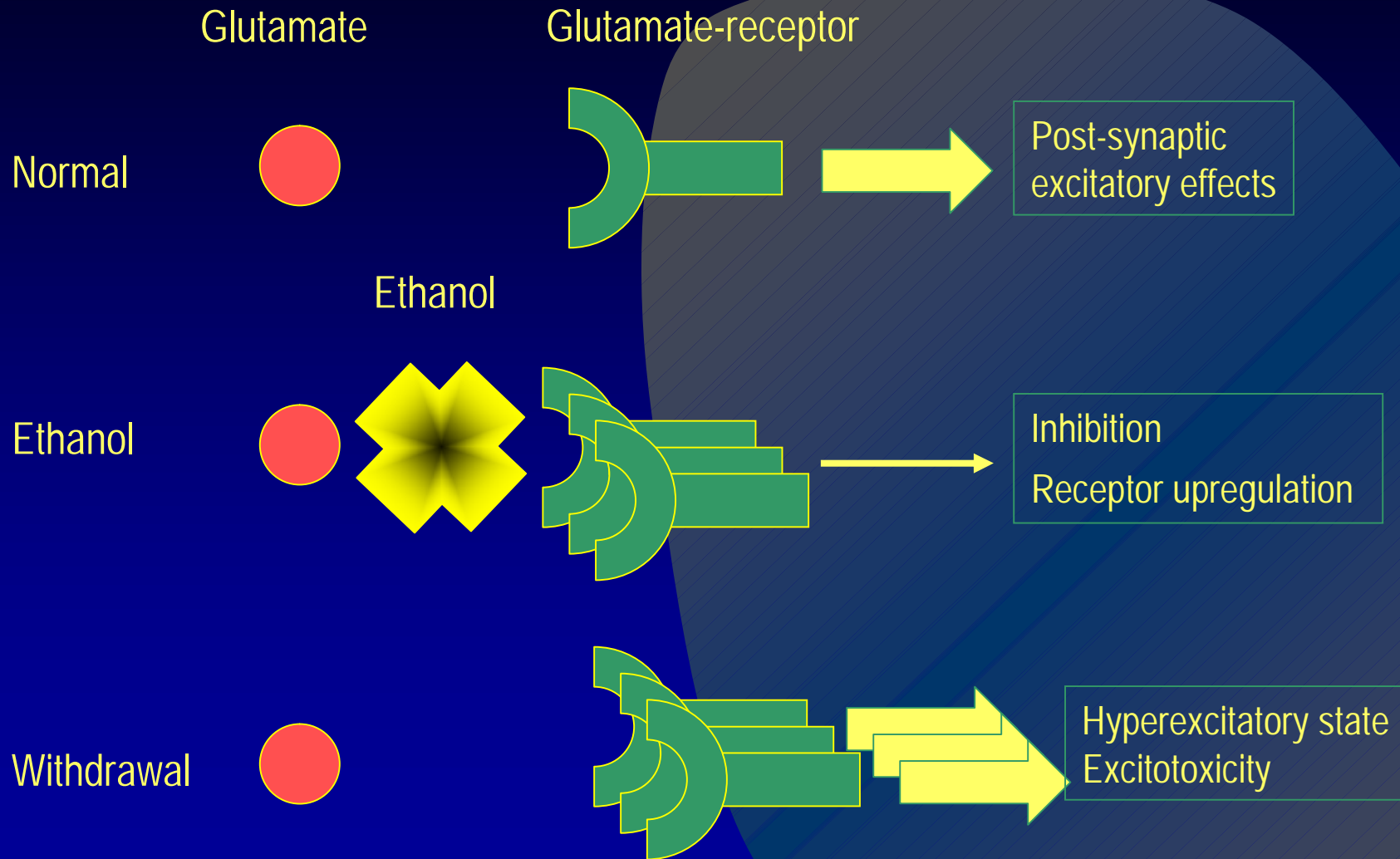

Anti-craving drugs: Effect of acamprosate on NMDA receptor activity and withdrawal

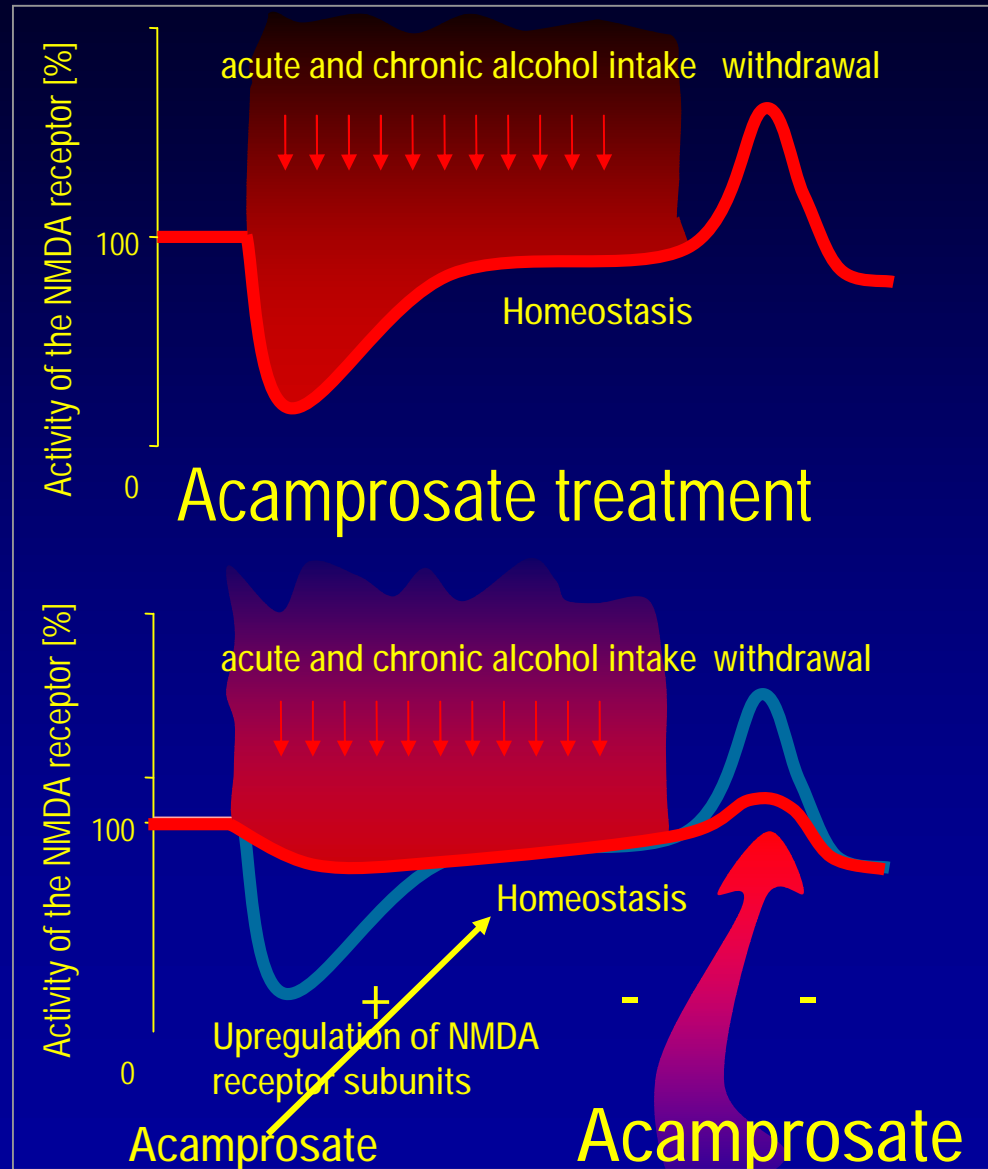

Glutamatergic neurotransmission

(candidate genes selected for analysis are indicated by a bold frame)

Animal models:

	Intake	Preference	Sensitivity	Tolerance	Withdrawal	Relapse
NR2B					X	
mGluR5	X					X
PTK fyn			X	X		
nNOS	X	X				
PRKG2	X		X			
CamK 4				X		
CREB	X					
NR1			X			
NR2A	X		X			
PI3K		X				
PRKG2	X		X			
GLAST	X					

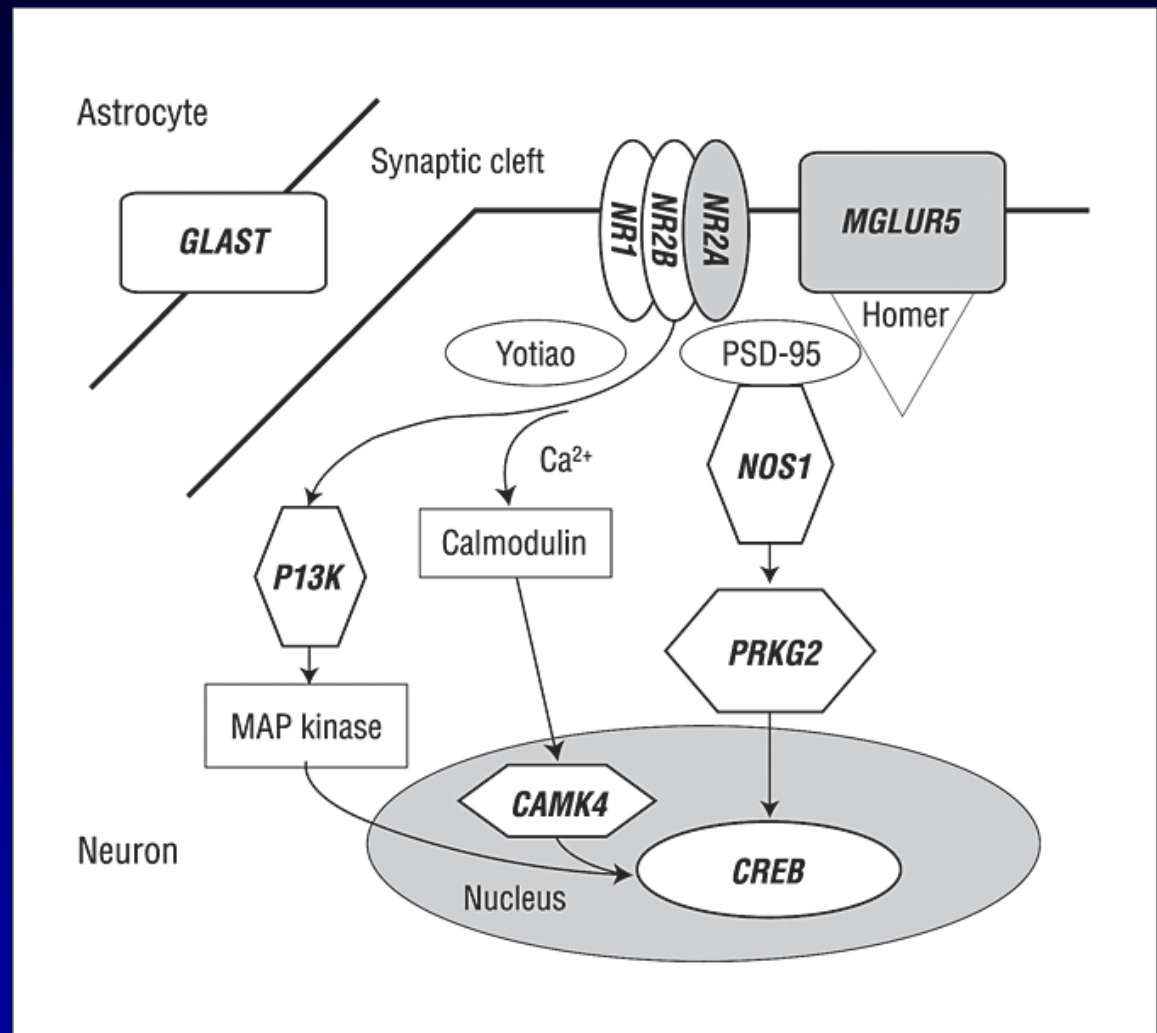

Schumann, G. et al. Arch Gen Psychiatry 2008;65:826-838.

Schematic representation of the genomic organization of NR2A and mGluR5

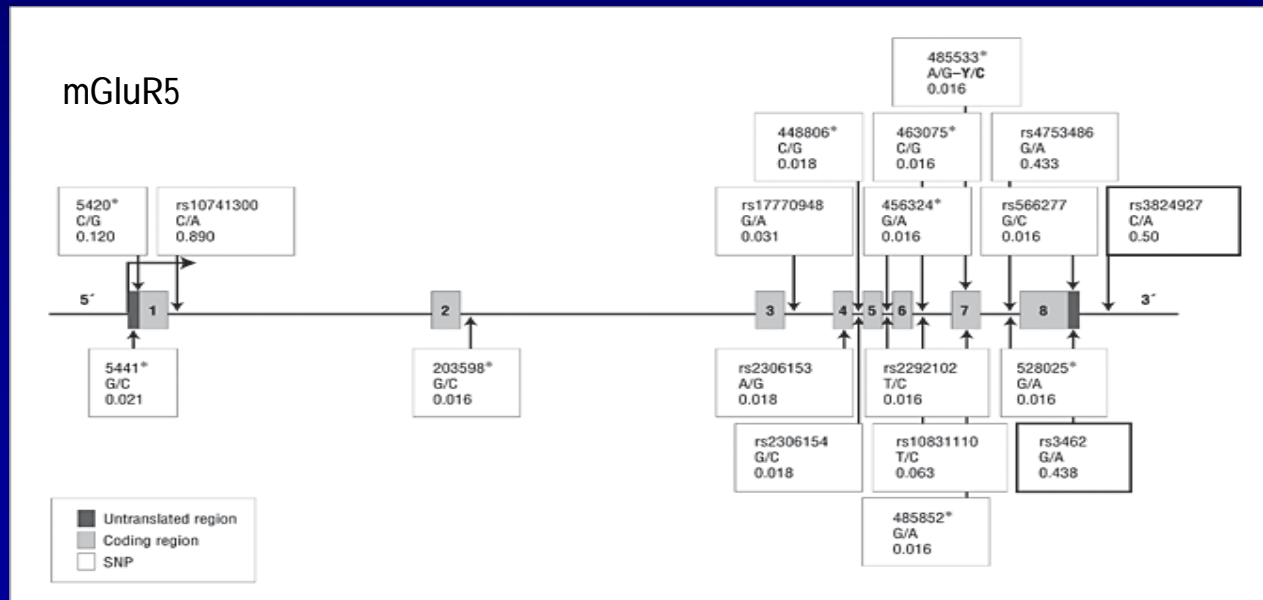
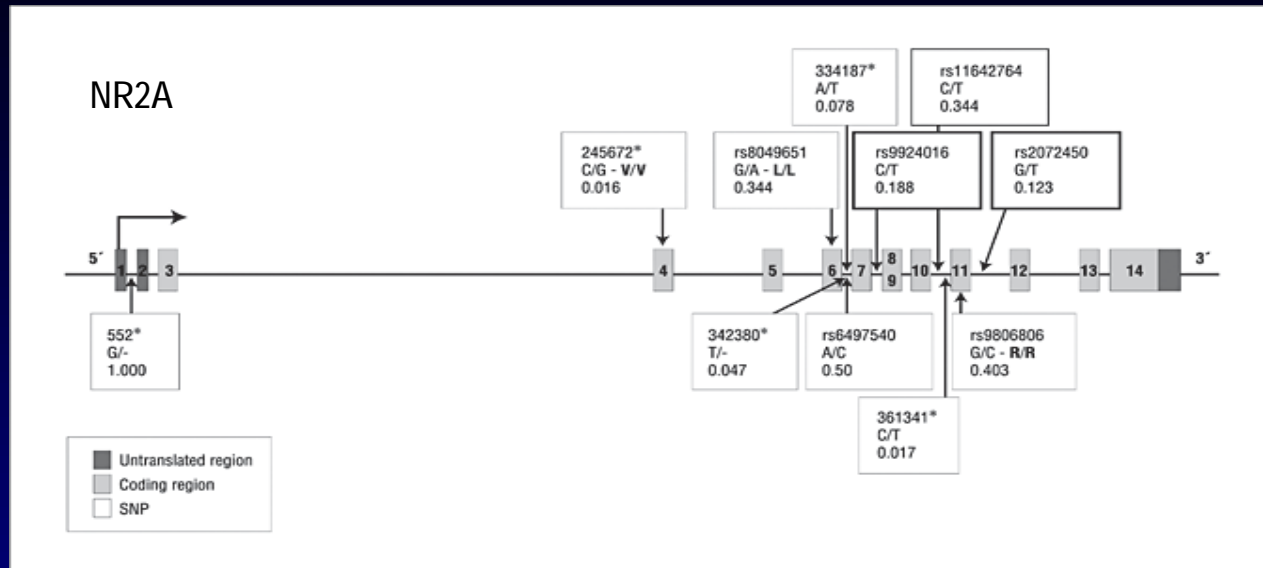

Alcohol-Dependent Adult Patients and Controls and Adolescent Trio Sample

Table 1. Alcohol-Dependent Adult Patients and Controls and Adolescent Trio Sample

Participant	No. of Participants	Age, Mean (SD), y	Sex, %	
			M	F
Study 1 Sample				
Patients	544	42.62 (9.54)	77.3	22.7
Controls	553	44.68 (13.96)	51.2	48.8
Study 2 Sample				
Patients	793	43.58 (9.93)	77.8	22.2
Controls	1002	47.96 (15.53)	59.6	40.4
Adolescent Trio Sample^a				
Adolescents	144	14.99 (0.37)	53.1	46.9

^aAdolescent sample consisted of 142 complete trios and 2 incomplete trios (only offspring and mother).

Comparison of Severity of Alcohol Dependence in Study 1 vs Study 2

Table 6. Comparison of Severity of Alcohol Dependence in Study 1 vs Study 2^a

No. of <i>DSM-IV</i> Symptoms	No. of Patients (%)	
	Sample 1 (N=345)	Sample 2 (N=793)
3	27 (7.83)	36 (4.5)
4	43 (12.46)	58 (11.9)
5	66 (19.13)	129 (16.3)
6	65 (18.84)	155 (19.5)
7	144 (41.74)	415 (52.3)

^a Mean number of symptoms was 5.742 in study 1 and 6.078 in study 2 ($P < .001$, analysis of variance).

Statistical modeling overview

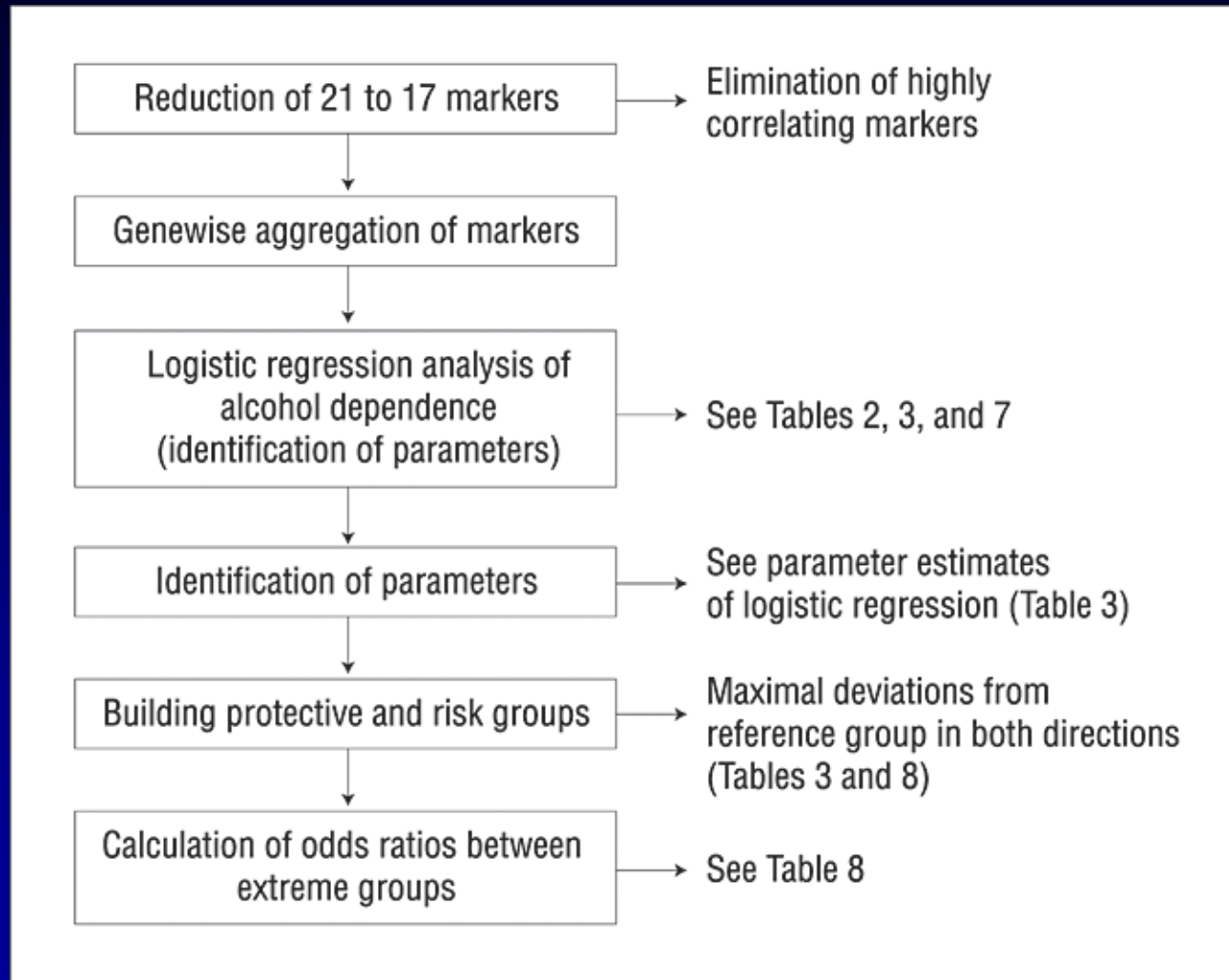

Gene-wise multiple logistic regression analysis

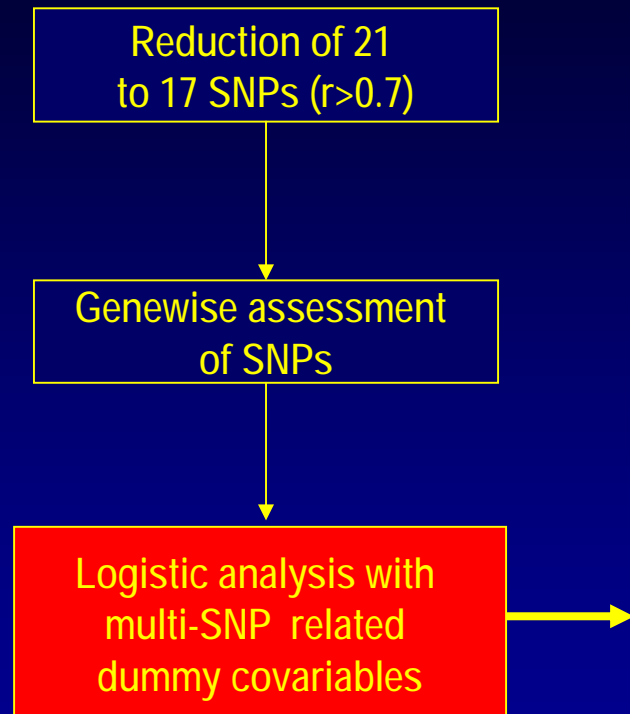

Table 2. Genewise Multiple Logistic Regression of Alcohol Dependence^a

Gene	Wald χ^2	df	P Value ^b
<i>MGLUR5</i>	9.9908	5	.08
<i>NR2A</i>	9.7770	5	.08
<i>PIK3R1</i>	9.5969	6	.14
<i>CAMK4</i>	10.1689	7	.18
<i>PRKG2</i>	2.6170	2	.27
<i>GLAST</i>	4.9746	5	.42
<i>NOS1</i>	1.0049	2	.61
<i>CREB1</i>	0.3591	2	.84
<i>NR1</i>	0.1980	2	.91
<i>NR2B</i>	0.1593	2	.92

^a Genotypes of all markers were within Hardy-Weinberg equilibrium.

^b Results from testing the null hypothesis (ie, none of the multilocus genotypic groups within a gene differ from reference group).

Identification and Analysis of Extreme Genotypes for Alcohol Dependence in Study 1 and Study 2

Logistic regression analysis

Table 8. Identification and Analysis of Extreme Genotypes for Alcohol Dependence in Study 1 and Study 2

Gene	Genotype 1	Genotype 2	Study 1				Study 2				Total		
			Affected Individuals, No.	Controls, No.	OR (95% CI)	P Value ^a	Affected Individuals, No.	Controls, No.	OR (95% CI)	P Value ^a	OR (95% CI)	P Value ^b	
<i>NR2A</i>	Risk	rs2072450 CC	rs9924016 Del/Del	202	172	2.35 (1.37-4.03)	.002	60	58	2.01 (1.15-3.50)	.02	2.18 (1.48-3.21)	< .001
	Protective	AC	Del/Ins	23	46			32	62				
<i>MGLUR5</i>	Risk	rs3462 GG	rs3824927 CC	83	61	1.69 (1.06-2.69)	.03	118	155	0.92 (0.66-1.27)	.62	1.13 (0.86-1.47)	.38
	Protective	GA	CA	66	82			137	165				

Abbreviations: CI, confidence interval; OR, odds ratio.

^aFisher exact test.

^bCochran-Mantel-Haenszel test.

Schumann, G. et al. 2008

Calculating Odds Ratios between „extreme groups“

Association Analysis and Replication of NR2A With Genetically Enriched Phenotypes of Alcohol Dependence

Table 9. Association Analysis and Replication of NR2A With Genetically Enriched Phenotypes of Alcohol Dependence

Measure	Study 1				Study 2				Total	
	Affected Individuals, No.	Controls, No.	OR (95% CI)	P Value ^a	Affected Individuals, No.	Controls, No.	OR (95% CI)	P Value ^a	OR (95% CI)	P Value ^b
Age at onset < 25 y										
Risk	34	172		.001 ^c	50	58	2.67 (1.42-5.02)	.002	3.69 (2.0-6.81)	< .001
Protective	0	46			20	62				
Positive family history										
Risk	53	172	3.54 (1.22-10.3)	.01	51	58	2.37 (1.29-4.36)	.007	2.68 (1.58-4.54)	< .001
Protective	4	46			23	62				
Maximum No. of drinks										
Risk	29	172		.35	36	58	3.21 (1.52-6.76)	.002	2.70 (1.45-5.03)	.001
Protective	4	46			12	62				

Abbreviations: CI, confidence interval; OR, odds ratio.

^aFisher exact test.

^bCochran-Mantel-Haenszel test.

^cCalculation of OR is not possible owing to empty cell in contingency table.

Mannheim risk children study

Prospective study from birth to adolescence
(N= 384; 185 boys, 199 girls)

Risk groups
0= none
1= moderate
2= high risk

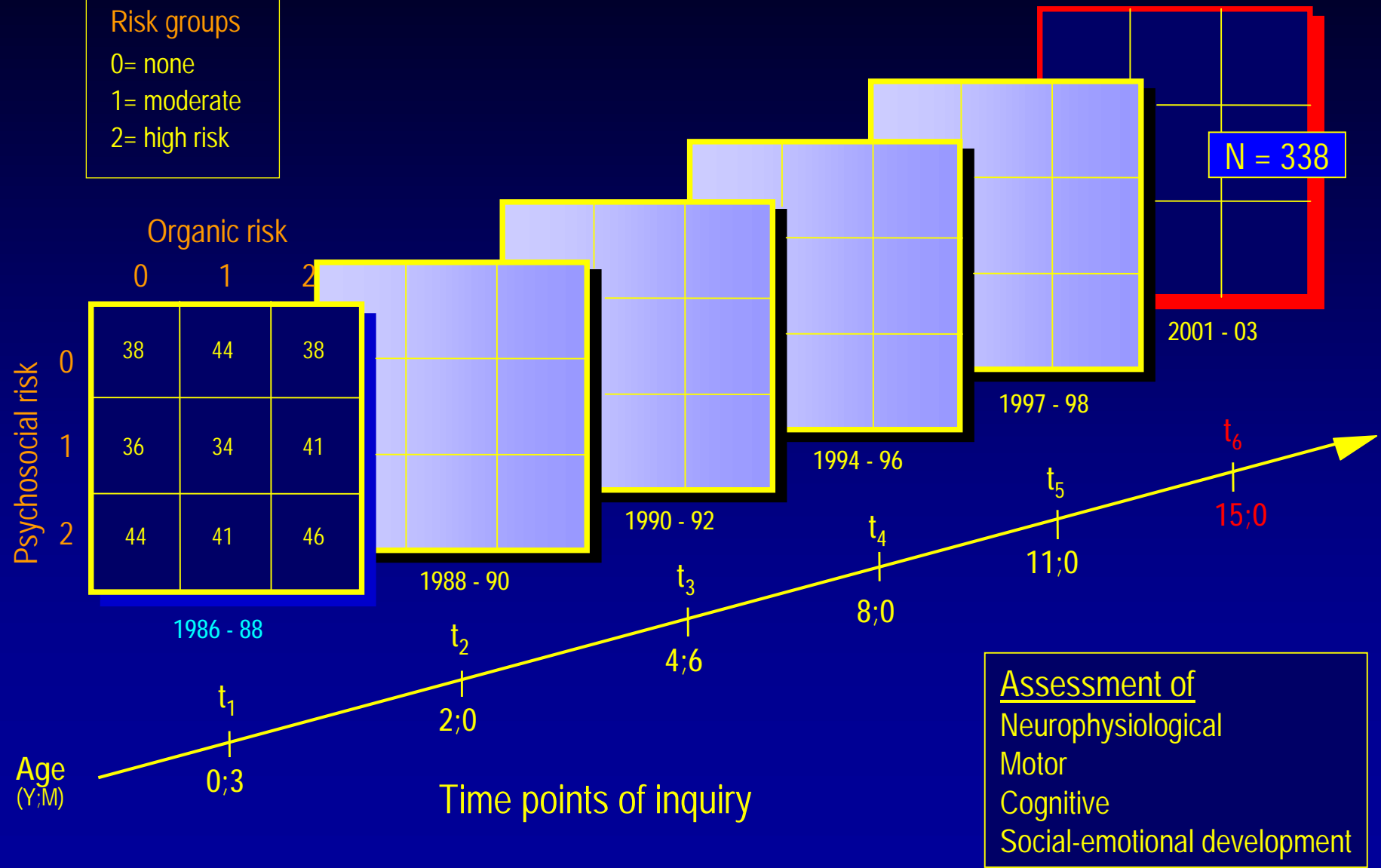

Analysis of the Role of NR2A in Initiation and Risky Drinking in Adolescent Trios

Table 10. Analysis of the Role of NR2A in Initiation and Risky Drinking in Adolescent Trios

Measure	Not Randomly Transmitted Allele/Haplotype	T:U Ratio	Total LRS	P Value
Lifetime prevalence drunkenness				
rs2072450	C	17:7	4.296	.04
rs11642764	A	24:20	0.364	.55
Maximal amount of drinking/occasion (median split)				
rs2072450	C	23:10	5.263	.02
rs11642764	A	29:19	2.099	.15

Abbreviations: LRS, likelihood ratio statistic; T:U, transmitted to untransmitted.

Schumann, G. et al. 2008

Conclusion:

Genetic variations in NR2A have the greatest relevance for human alcohol dependence among the glutamatergic genes selected for their known alteration of alcohol effects in animal models.

Does phosphatidylinositol 3-kinase p85 (PIK3R) contribute to patterns of risky alcohol drinking in adolescents ?

We investigated genetic variations in PIK3R in 145 family trios consisting of 15-16 year old adolescents and their parents.

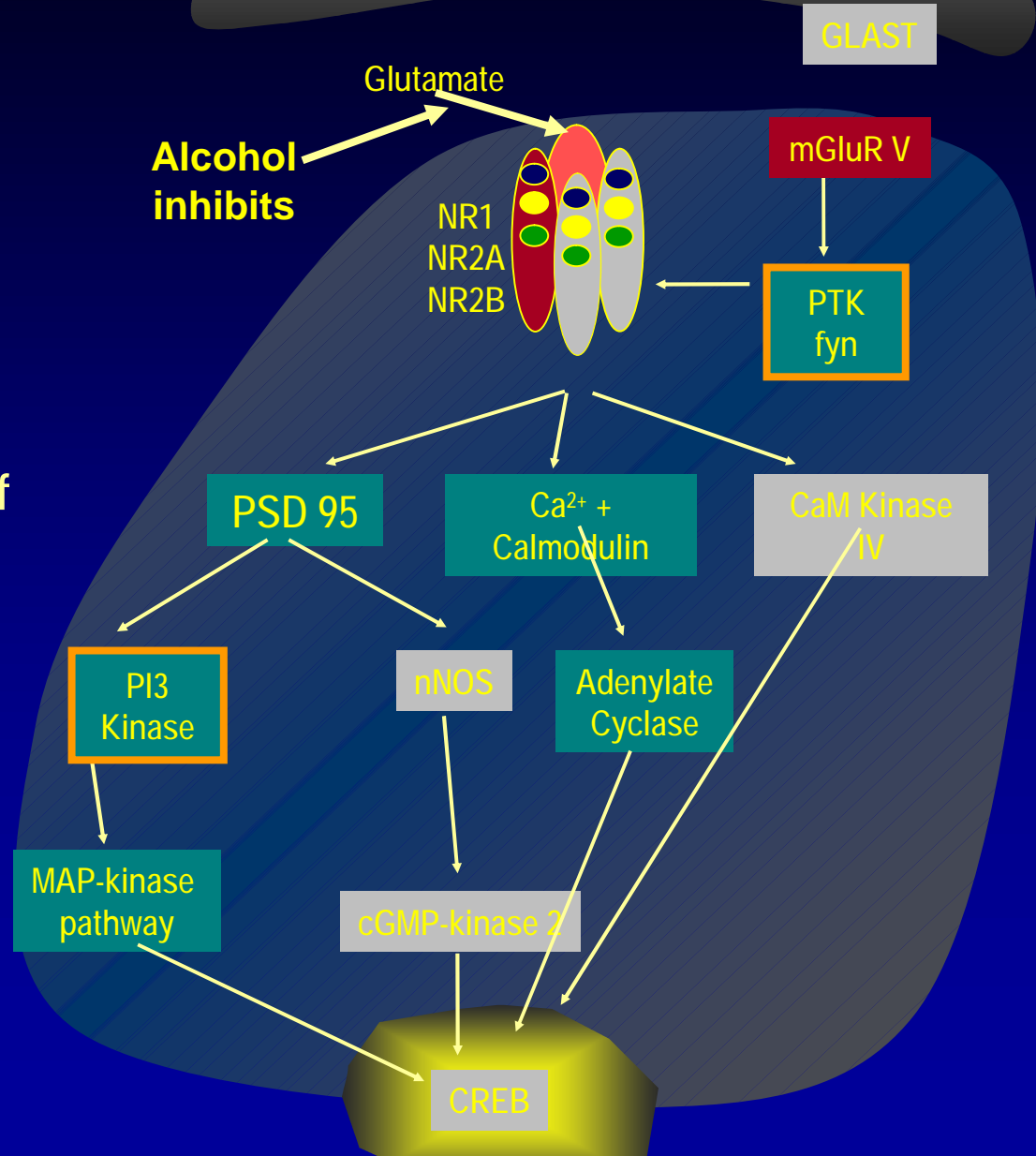

Genomic organization, SNPs and haplotypes of PIK3R

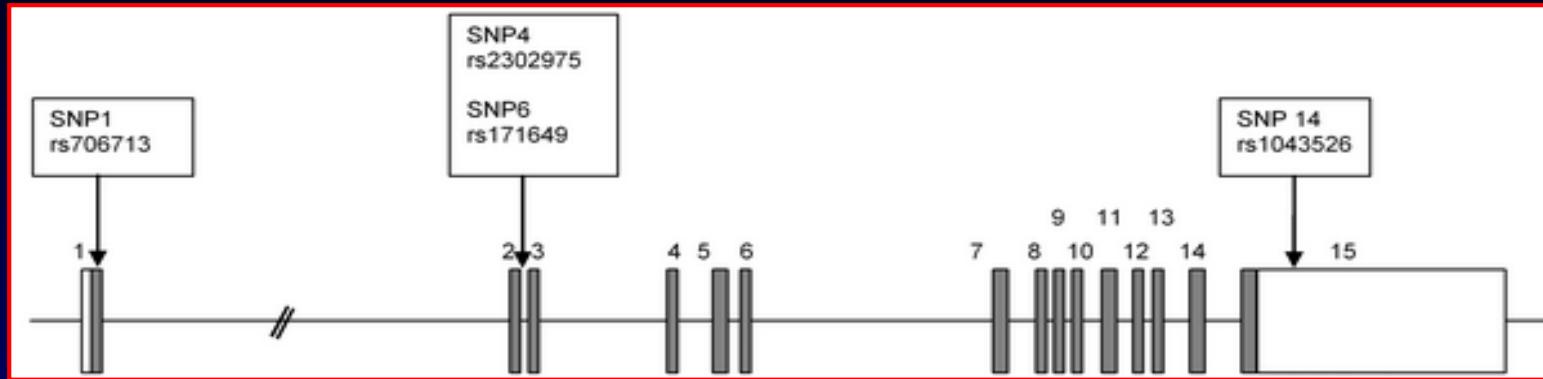

Haplotypes						
	1	2	3	4	5	6
SNP #						
1 (rs706713)	0	0	1	0	0	0
2 (rs706714)	0	0	1	0	0	0
3 (rs2302974)	0	0	1	0	1	1
4 (rs2302975)	0	1	1	0	1	1
5 (rs2302976)	0	0	1	0	1	1
6 (rs171649)	1	0	0	0	0	0
7 (rs3730082)	0	1	0	0	0	0
8 (rs16897620)	0	0	1	0	1	1
9 (rs3815701)	0	0	1	0	1	1
10 (novel)	0	0	1	0	0	0
11 (rs3730089)	0	0	0	0	0	0
12 (rs895304)	0	0	0	0	0	0
13 (rs3730073)	0	0	0	0	0	0
14 (rs1043526)	0	0	0	0	1	0
Frequency	0.2726	0.1682	0.0625	0.0585	0.0469	0.0463

Haplotype tagging SNPs are indicated in bold. (0) indicates the allele with major frequency, (1) the allele with minor frequency.
doi:10.1371/journal.pone.0001769.t003

Gender-specific association of PI3Kinase htSNPs with risky drinking behaviour in adolescents

Lifetime prevalence drunkenness

Maximum amount of drink/occasion

SNP	Alleles	Males (n = 77)			Females (n = 68)			Total (n = 145)		
		T:U	OR (95% CI)	P-value	T:U	OR (95% CI)	P-value	T:U	OR (95% CI)	P-value
<i>Lifetime prevalence drunkenness^a</i>										
1 (rs706713)	T	12:11	1.1152 (0.4464-2.7858)	0.8154	9:10	0.8743 (0.3163-2.4167)	0.7955	21:21	1 (0.50681-2.733)	1.0000
	C	45:46			35:34			80:80		
4 (rs2302975)	G	31:15	3.3893 (1.5350-7.4836)	0.0019	20:19	1.0965 (0.4727-2.5435)	0.8301	51:34	2.02 (1.1426-3.5727)	0.0148
	A	25:41			24:25			49:66		
6 (rs171649)	A	21:30	0.5200 (0.2447-1.1052)	0.0870	17:16	1.1050 (0.4601-2.6536)	0.8232	38:46	0.7159 (0.4057-1.2633)	0.2479
	G	35:26			25:26			60:52		
11 (rs3730089)	G	49:51	0.6863 (0.2041-2.3078)	0.5403	35:39	0.4986 (0.1525-1.6301)	0.2409	84:90	0.5833 (0.2508-1.3560)	0.2053
	A	7:5			9:5			16:10		
14 (rs1043526)	G	13:5	3.0426 (1.0103-9.163)	0.0379	7:10	0.6432 (0.2201-1.8794)	0.4169	20:15	1.4127 (0.6788-2.9399)	0.3534
	A	47:55			37:34			84:89		
<i>Maximum amount of drinking/occasion^b</i>										
1 (rs706713)	T	12:15	0.7538 (0.3211-1.77)	0.5154	9:11	0.7801 (0.2930-2.0773)	0.6185	21:26	0.7652 (0.4022-1.4559)	0.4137
	C	52:49			43:41			95:90		
4 (rs2302975)	G	34:17	3.1333 (1.4030-6.9724)	0.0020	19:24	0.6717 (0.3065-1.4733)	0.319	53:41	1.5389 (0.8080-2.6093)	0.1082
	A	30:47			33:28			63:75		
6 (rs171649)	A	25:32	0.641 (0.3178-1.2930)	0.2127	25:19	1.6316 (0.7361-3.6163)	0.2262	50:51	0.9651 (0.5722-1.6276)	0.8939
	G	39:32			25:31			64:63		
11 (rs3730089)	G	56:56	1 (0.3292-3.0380)	1	44:47	0.5851 (0.1779-1.9245)	0.3718	100:103	0.7767 (0.3464-1.7415)	0.5385
	A	7:7			8:5			15:12		
14 (rs1043526)	G	14:6	2.6923 (0.9651-7.5108)	0.0494	8:15	0.4485 (0.1712-1.1749)	0.0960	22:21	1.0585 (0.5464-2.0504)	0.8661
	A	52:60			44:37			96:97		

T = transmitted, U untransmitted
^aSubject has never been drunk vs. has been drunk
^bMedian split at 16 g alcohol
doi:10.1371/journal.pone.0001769.t004

Conclusions:

Our findings highlight a previously unknown relevance of PIK3R1 genotypes for alcohol use disorders and might help discriminate individuals at risk for alcoholism.

Are Genetic Variations of Protein Tyrosine Kinase fyn associated with Alcohol Dependence ?

Increased tolerance to the effects of alcohol was shown to be associated with an increased risk for alcoholism in humans and was observed in protein tyrosine kinase (PTK) fyn knockout mice.

We carried out an association analysis of PTK fyn genotypes in sample 1 (Mainz and Muenchen).

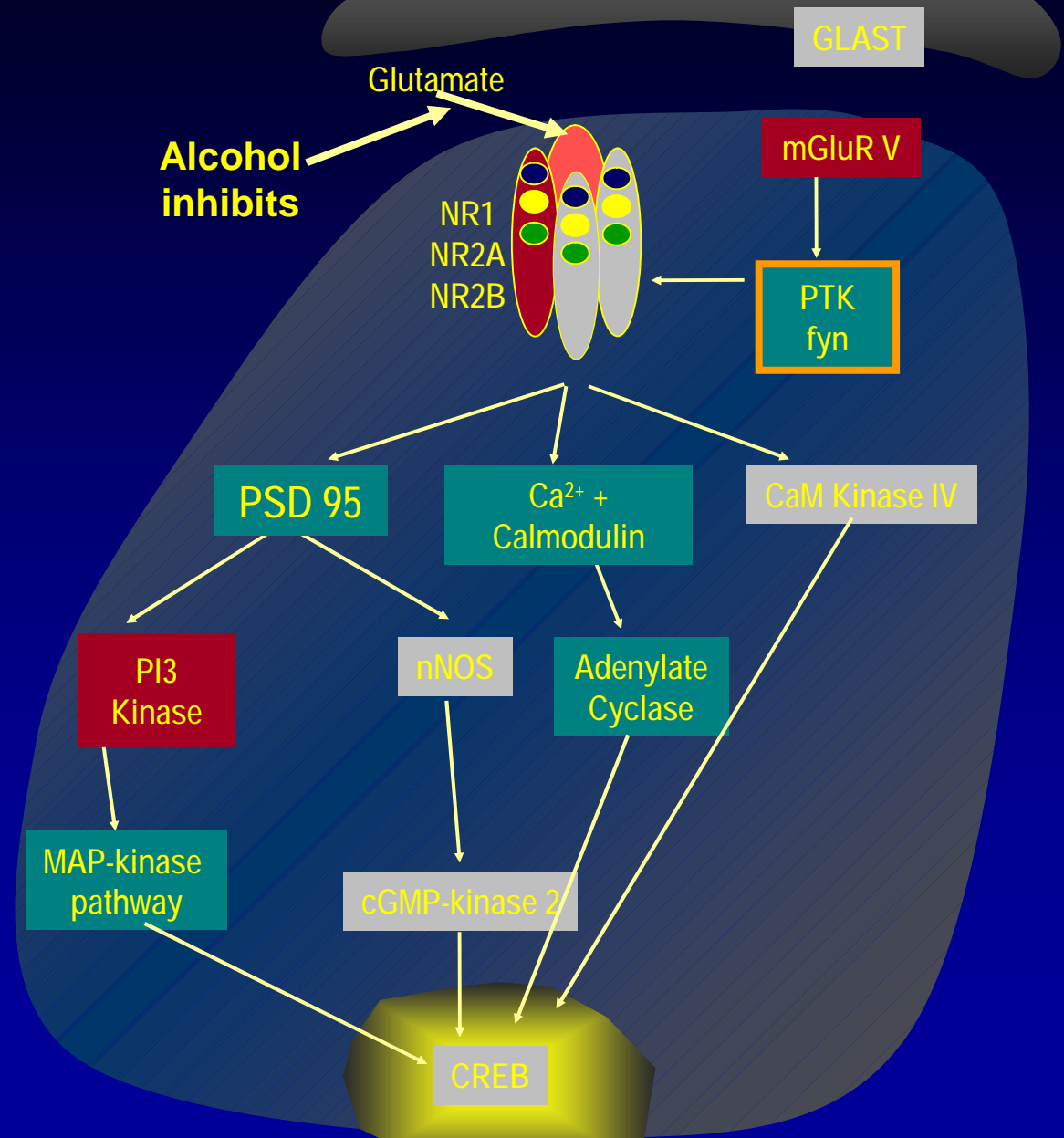

Protein Tyrosine Kinase "fyn":

Comparison of Genotypes and Allele Frequencies of SNP T137346

	Armitage-Trend Test (Two-Sided) for Testing Genotype Distribution		OR	CI (OR)	χ^2 Test (Two-Sided) for Testing Differences in Allele Frequencies	<i>p</i>
All	z = 2.35	<i>p</i> = .020	1.33	1.05-1.67	$\chi^2 = 5.63$.018
Munich	z = 1.73	<i>p</i> = .089	1.32	.96-1.81	$\chi^2 = 2.99$.084
Mainz	z = 1.01	<i>p</i> = .353	1.22	.84-1.79	$\chi^2 = 1.08$.299

SNP, single nucleotide polymorphism; OR, odds ratio; CI, confidence interval.

Genotype Frequencies of SNP T137346C in Selected Phenotypes

	Genotypes of Patients <i>n</i> (%)				Genotypes of Control Subjects <i>n</i> (%)				Armitage-Test (One-Sided) Patients vs. Control Subjects
	TT	TC	CC	Total	TT	TC	CC	Total	
High Number of Withdrawal Symptoms									
All	97 (53.6)	70 (38.7)	14 (7.7)	181	228 (62.5)	117 (32.1)	20 (5.5)	365	2.00 (<i>p</i> = .027)
Munich	36 (48.0)	33 (44.0)	6 (8.0)	75	167 (63.0)	86 (32.5)	12 (4.5)	265	2.38 (<i>p</i> = .013)
Mainz	61 (57.5)	37 (34.9)	8 (7.5)	106	61 (61.0)	31 (31.0)	8 (8.0)	100	.34 (<i>p</i> = .410)
High Alcohol Intake (>300 g/day)									
Munich	27 (41.5)	34 (52.3)	4 (6.2)	65	167 (63.0)	86 (32.5)	12 (4.5)	265	2.84 (<i>p</i> = .004)
High Maximum Number of Drinks (>600 g/24 hours)									
Munich	37 (45.7)	39 (48.2)	5 (6.17)	81	167 (63.0)	86 (32.5)	12 (4.5)	265	2.54 (<i>p</i> = .008)

Conclusions:

Our results indicate a possible association of alcohol dependence and alcohol dependence phenotypes with a genotype of the SNP T137346C of the PTK fyn.

Conclusions

GLAST

Glutamate

mGluR V

NR1
NR2A
NR2B

PTK fyn

PSD 95 Ca²⁺ + Calmodulin CaM Kinase IV

PI3
Kinase

nNOS

Adenylate
Cyclase

MAP-kinase
pathway

cGMP-kinase 2

CREB

We performed an identification and genetic analysis of variations of glutamatergic signal transduction in alcohol dependent patients and adolescents.

We have identified NR2A as the most relevant gene for human alcohol dependence among the glutamatergic genes selected for their known alteration of alcohol effects in animal models.

Additional genes which showed an association with relevant phenotypes and specific samples included mGluR5, PIK3R and PTK fyn.

The observation of partial but not complete overlap of association patterns with status compared to specific phenotypes underscores the genetic heterogeneity of alcohol abuse and dependence.

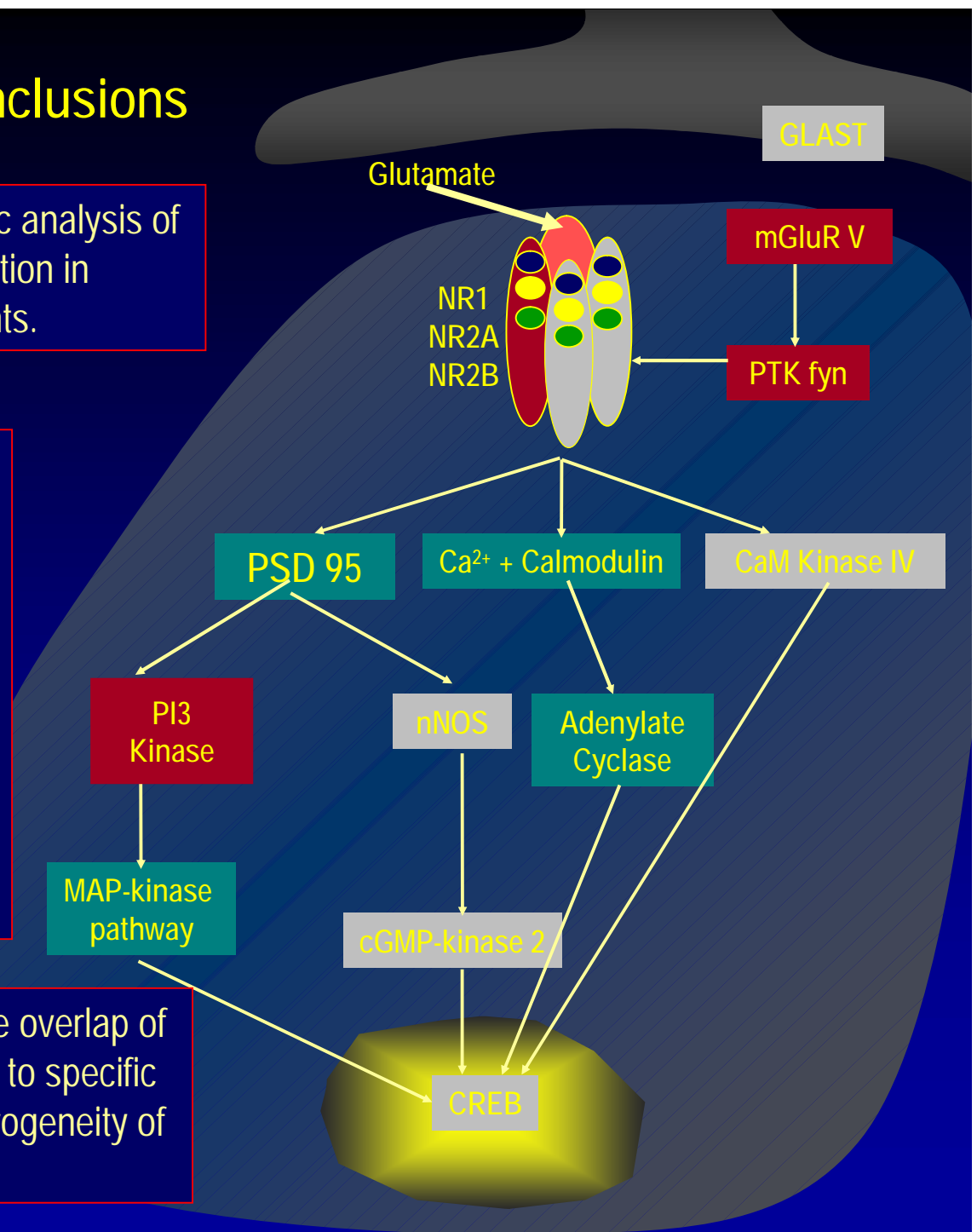

Institute of Psychiatry, King' s College London

Section of Addiction Biology

Gerome Breen

Mira Buehler

Natalie Castellanos

Toni Kim Clarke

Patricia Conrod

Emma Dempster

Sylvane Desrivieres

Francesca Ducci

Li Dong

Shadi Hessami

Kristina Krause

Anbarasu Lourdusamy

Eva Loth

Christian Mueller

Inti Pedroso

Sylvia Peters

Laurence Reed

Christina Schilling

Maren Struve

Chloe Wong

Vagelis Zois

Acknowledgements

Central Institute of Mental Health, Mannheim

Dept. of Child Psychiatry

Manfred Laucht

Dorothea Blomeyer

Dept. of Behavioural Pharmacology

Rainer Spanagel

Dept. of Addiction Medicine

Karl Mann

Michael Smolka

Imperial College, London

Marjo-Ritta Jarvelin

Coin Lachlan

Paul Elliott

Scripps Research Institute

George Koob

INIA West consortium

Cambridge University

Trevor Robbins

Jeff Dalley

Uppsalla University

Georgi Bakalkin

University of Munich

Michael Soyka

Funding provided by

EC-FP6 Integrated Project

"IMAGEN"

NIHR-Biomedical Research

Centre "Mental Health"

National Genome Research

Network (D)

Addiction Research Network (D)



Genewise Identification of Risk vs Protective Multilocus Genotypes

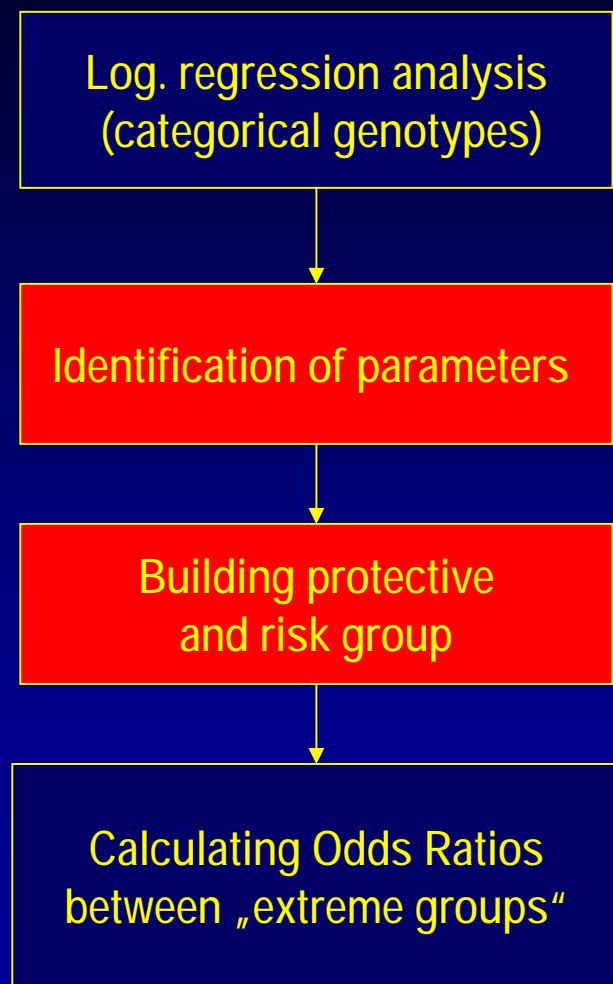

Table 3. Genewise Identification of Risk vs Protective Multilocus Genotypes^a

Genotype	Odds Ratio (95% Confidence Interval)
<i>NR2A</i> rs9924016-rs2072450	
DelIns-CC	1 [Reference]
DelDel-CC ^b	1.234 (0.877-1.735)
DelDel-AC	1.066 (0.679-1.672)
DelIns-AC ^c	0.503 (0.272-0.933)
InsIns-CC	0.926 (0.511-1.676)
All other	1.787 (0.595-5.366)
<i>MGLUR5</i> rs3462-rs3824927	
GG-CA	1 [Reference]
GG-AA	0.834 (0.572-1.218)
GG-CC ^b	1.252 (0.798-1.965)
GA-CA ^c	0.723 (0.468-1.119)
GA-CC	1.151 (0.701-1.891)
All other	3.895 (1.010-15.018)

^aOdds ratio estimates for *NR2A* and *MGLUR5* genotypes taken from full logistic regression model comprising all 17 markers of all 10 genes. Reference group is most frequent multilocus genotype of each gene. Small categories (groups that comprise < 5% of whole sample for a particular genotype) are pooled into 1 category and excluded from risk group selection.

^bRisk group for alcohol dependence.

^cProtective group.

Haplotypes of GRIN2A and GRM5a

Table 7. Haplotypes of *GRIN2A* and *GRM5*^a

<i>GRIN2A</i>						
Haplotype frequency	0.3537	0.1762	0.1250	0.1064	0.0891	0.0319
Haplotype						
CNG 552	1 ^b	1 ^b	- ^b	1 ^b	1 ^b	1
CNG 245272	0 ^b	0 ^b	0 ^b	0 ^b	0 ^b	0
rs6049651	0	1	-	0	0	1
CNG 534187	0 ^b	0 ^b	0 ^b	0 ^b	0 ^b	0
CNG 542380	0 ^b	0 ^b	0 ^b	0 ^b	0 ^b	0
rs6497540	0	1	-	1	0	1
rs8924016	0	0	-	0	0	0
rs11842764	0	1	-	0	0	0
rs35524162	0 ^b	0 ^b	0 ^b	0 ^b	0 ^b	0
rs6805806	0	1	-	0	0	0
rs2072450	0	0	0	0	1	0
<i>GRM5</i>						
Haplotype frequency	0.3451	0.3257	0.0508	0.030		
Haplotype						
CNG 5492	0 ^b	0 ^b	0 ^b	0		
CNG 5441	0 ^b	0 ^b	0 ^b	0		
rs10741300	1	1	-	1		
CNG 208598	0 ^b	0 ^b	0 ^b	0		
rs17770948	0	0	0	0		
rs2303153	0	0	0	0		
CNG 448306	0 ^b	0 ^b	0 ^b	0		
rs2305154	0	0	0	0		
CNG 456324	0 ^b	0 ^b	0 ^b	0		
rs2292102	0	0	0	0		
CNG 463275	0 ^b	0 ^b	0 ^b	0		
rs10831110	0	0	0	0		
CNG 485533	0 ^b	0 ^b	0 ^b	0		
CNG 485552	0 ^b	0 ^b	0 ^b	0		
rs4753486	0	1	0	1		
CNG 528225	0 ^b	0 ^b	0 ^b	0		
rs566277	0	0	0	0		
rs2462	1	0	0	1		
rs3824827	0	1	0	1		

Abbreviation: CNG, Centre National de Génotypage.

^a Only common haplotypes ($\geq 5\%$ frequency) were considered for this study.

^b Markers that were newly discovered during resequencing do not contribute to the haplotypes of a frequency of 5% or greater in these 2 genes.

Mortality attributable to tobacco and alcohol as a percentage of total mortality in Germany (1997)

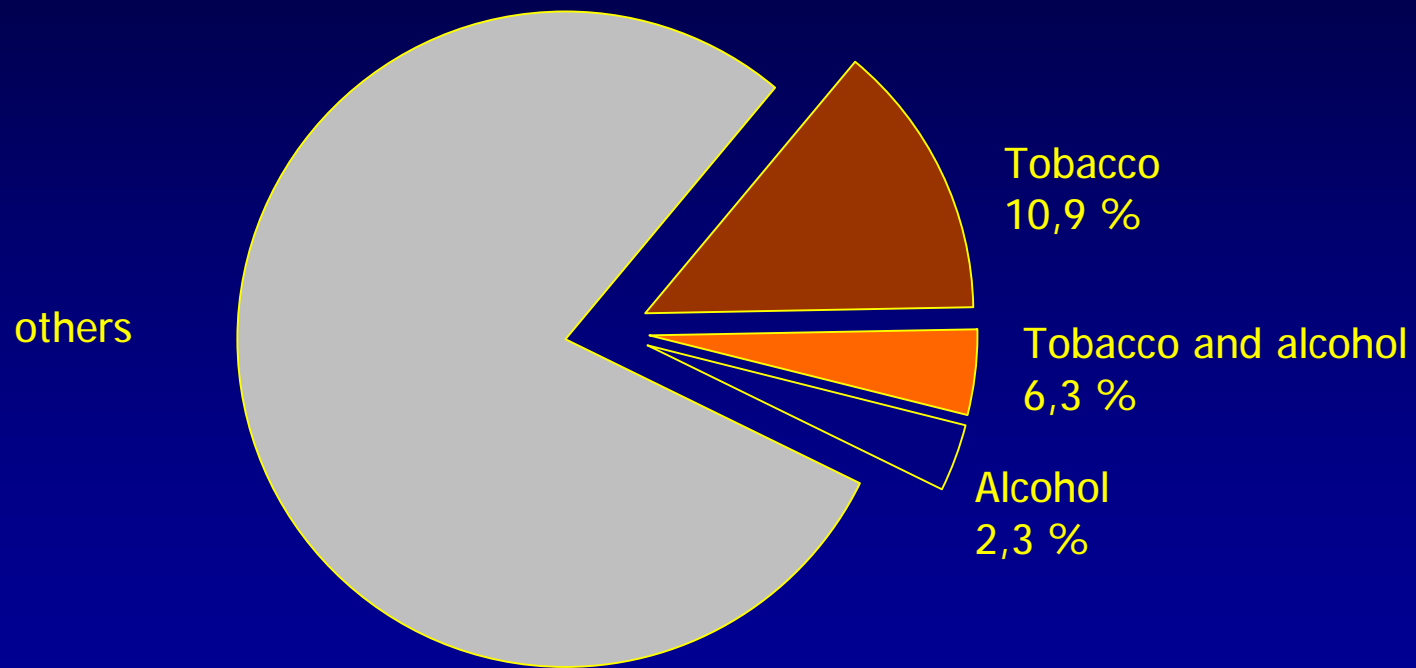

John & Hanke (2001)